



Mob: +91 7217885948

www.rfconnector.in

pradeep@rfconnector.in



www.rfconnector.in

CO30CAN KIT CONTACTLESS POWER & DATA

Product Manual

TM

Plot no. 845, DSIIDC Industrial Area KHASRA NO. 33/23 (0-7) & 37/4 (0-10) Gali no. 6, near Harnandi dharam kanta
Mundka Industrial Area, New Delhi, Delhi, 110041



CO30CAN KIT | 30W CAN CONTACTLESS POWER & DATA OVERVIEW

This document guides users on how to use the Co30CAN kit. The Co30CAN kit includes a transmitter (Tx) and receiver (Rx). Modules Tx and Rx are inductive couplers that supply power without physical contact power and data transmission, providing 30W at short range (few centimeters). This kit tests the benefits of contactless connectors by enabling cable limits and design barriers for more reliability and flexibility.

APPLICATIONS

Contactless connectors offer a new way to connect devices without physical cables or connectors, making it easier to link equipment in tight or moving spaces. This technology is ideal for industrial, defense, aerospace and medical applications.

For example:

- Changing out tools on robots can wear out the connectors, causing them to break or deform. Contactless connectors provide a more reliable, maintenance-free solution.
- In harsh or enclosed spaces like clean rooms, wired systems with open contacts are costly and can weaken the system. Contactless connectors offer a more reliable option, transferring power or data through non-conductive materials, including gases and liquids, without contact or drilling holes.

Use cases:

- Supply power through any non-electrically conducting material
- Supply power moving electronic systems
- Supply power to embedded electronic systems
- Enable new design (transfer through sealed enclosures)

FEATURES

- 30W continuous power transmission
- Bi-directional data transmission
- Short range contactless connectivity
- Misalignment tolerance
- Free movement due to no decoupling
- Used in pairs (transmitter Tx and receiver Rx)

BENEFITS

- No wear and tear
- Simplified interconnection
- No Wi-Fi or Bluetooth interface
- Not limited by mating cycle
- Maintenance free
- Provides immunity to vibration
- Provides immunity to contaminants, moisture and dust



KIT CONTENT ^[1]

Transmitter Tx	MU314610212300	Contactless Power & Data Transmitter 30W CAN 12 mm 24 VDC Rect. Screw	1
Receiver Rx	MU324610212300	Contactless Power & Data Receiver 30W CAN 12 mm 24 VDC Rect. Screw	1

REFERENCES

[1]	Datasheet, MU344610212400	Revision 1
[2]	Handout, MU344610212400	Revision 1
[3]	External Presentation, MU344610212400	Revision 1

SPECIFICATIONS

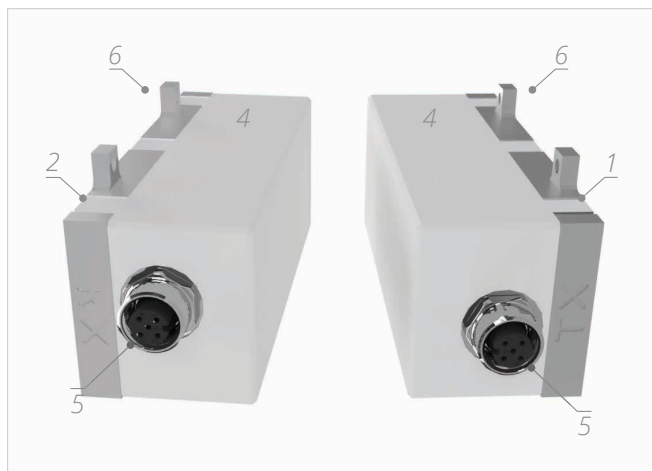

- 1. Transmitter (Tx)
- 2. Receiver (Rx)
- 3. Power Cable, M12 Female
- 4. Status LED
- 5. Cooling Fins
- 6. Wall Mounting

GENERAL SPECIFICATIONS

Tx Input Voltage	24	Vdc	± 10%	-
Rx Output Voltage	24	Vdc	± 5%	@ Load = 0 A
Input Current Max	1.66	A	-	@ Output Power = 30W, Z = 16 mm, X:Y = 2 mm
Rx Output Power	30	W	-	@ Z = 16 mm, X:Y = 2 mm
Maximum Capacitive Load	47	µF	-	-
Efficiency	75%		-	See Efficiency Section
Operating Indication	LED		-	See LED Indicators Section
Maximum Axial Distance	16	mm	-	See Air Gap & Misalignment Section
Minimum Axial Distance	8	mm	-	
Misalignment X,Y	± 2	mm	-	
Operational Readiness Power	1	s	-	-

DATA COMMUNICATIONS

Protocol	CAN 2.0A CAN 2.0B		
Data Rate	250	kbps	-
Latency	400	µs	-
Termination	No		120 Ohms on Request

Notes

1. Available in sample volumes only



MECHANICAL SPECIFICATIONS [1]

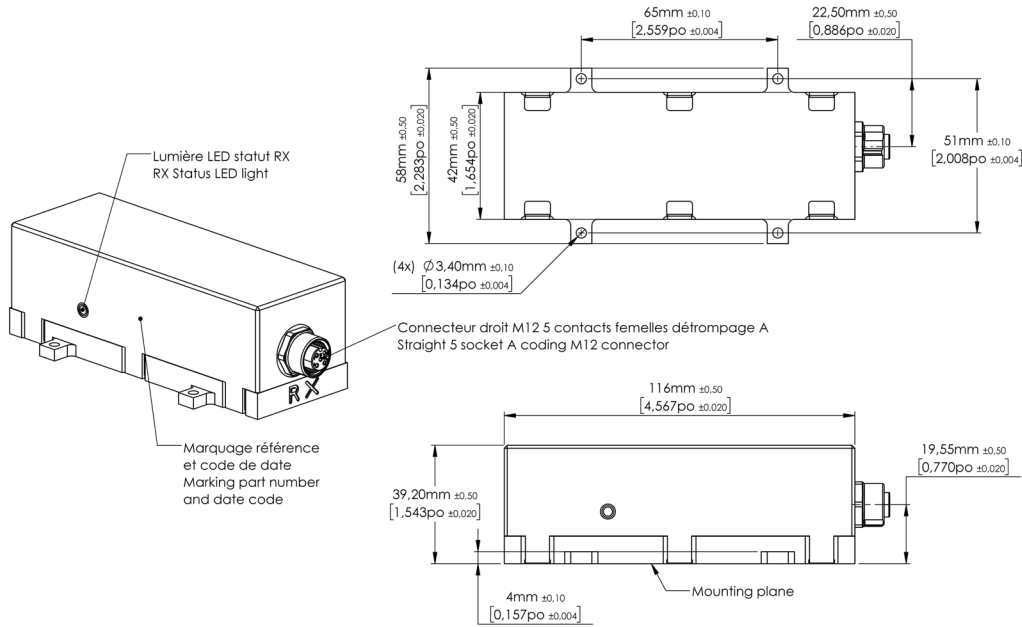

Size	116 x 58 x 40	mm	-
Typ. Weight	290	g	-
Case	Aluminum Alloy		
Top Cover	PET		

**RECOMMANDATIONS DE FIXATION SUR PANNEAU
 PANEL MOUNTING ADVICES**

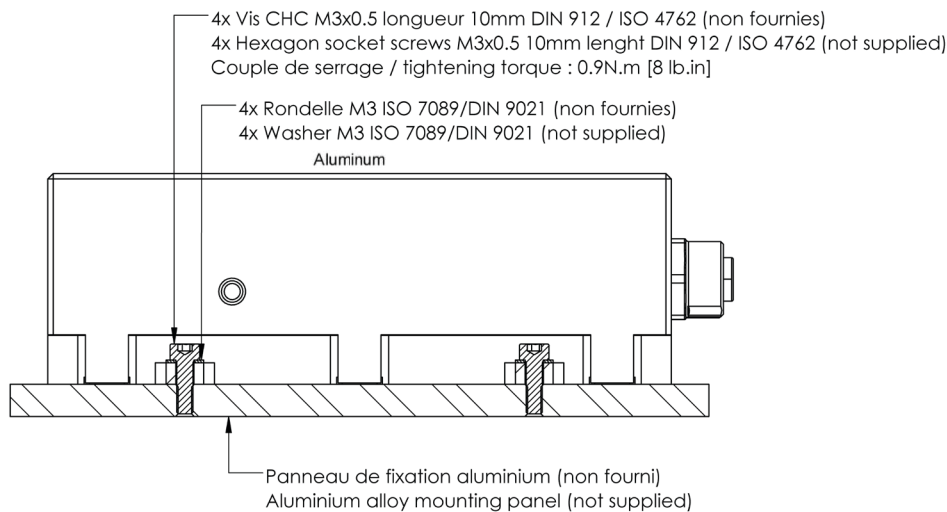

Notes

1. Tx and Rx have similar mechanical specifications.



AIRGAP & MISALIGNMENT

The system transmits contactless power at 8 to 16 mm for max power level of 30W.

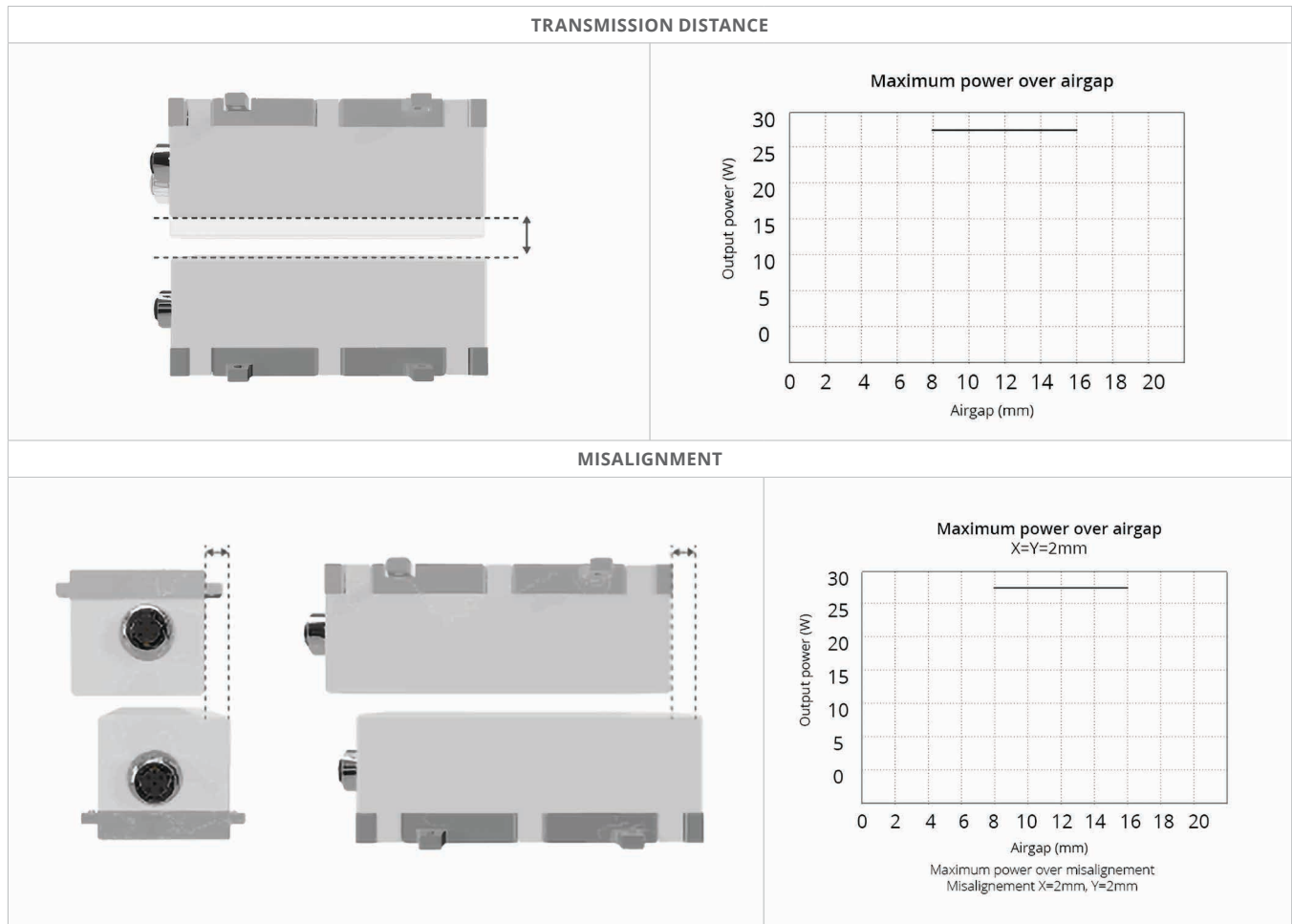

EFFICIENCY

75% of efficiency guarantee at 8 mm of transmission with the transmitter and receiver aligned.

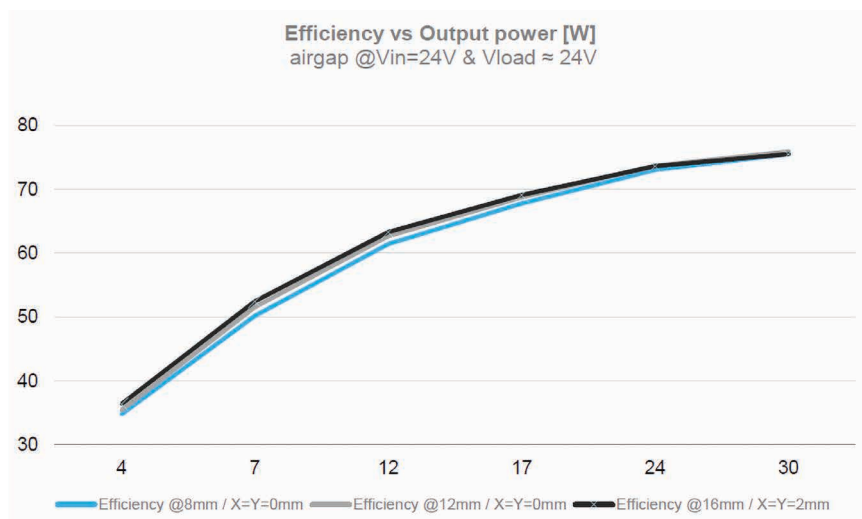



GUIDE

QUICK START

1. INSTALLATION

Fix the transmitter Tx and the receiver Rx following the mounting instructions.

2. POWER SUPPLY

To power the transmitter Tx and the receiver Rx, connect the power source to the Tx.

- Connect the transmitter Tx to power supply (24 VDC)
- Connect receiver Rx to a load by the connector M12 - see connector pinning

Do not use both power supply inputs at the same time as it could damage the attached modules and/or device.

3. INITIATE CONTACTLESS CONNECTIVITY

Align the transmitter Tx and the receiver Rx.

Following LEDs status that indicate the achieved power and/or data transmission:

- With a distance of transmission 12 mm \pm 4 mm
- With maximum misalignment of 2 mm (X:Y)

Do not place any conducting materials between the transmitter Tx and receiver Rx.

PAIRING

For proper communication, the transmitter Tx and receiver Rx must be synchronized. The kit comes with a pre-paired Tx and Rx. To connect a different Tx or Rx or replace a system, you will need to sync them manually. Contact technical support for assistance.

SAFETY INSTRUCTIONS & WARNING

The MU344610212400 is for evaluation only and does not meet CE conformity standards. It is intended solely for feasibility and testing in lab or development settings by qualified engineers or technicians due to the risks of handling electrical equipment.

REVISION HISTORY

DATE	REVISION	CHANGES
21/08/2024	1.0	Initial Version



Contactless Power & Data Transmitter + Receiver 30W CAN 8-16 mm 24 VDC Rect. Screw Kit

Version	30W CAN Contactless Power & Data
Part Number	MU344610212400
Type	MUCPDTR30WCAN12MM24DRBK00
Qty.	1

This user manual is valid for Co30CAN kit version 0.1 - MU344610212400. It provides guidelines to quickly understand the system and offers recommendations for users to achieve optimal performance for testing contactless power and data transmission.