

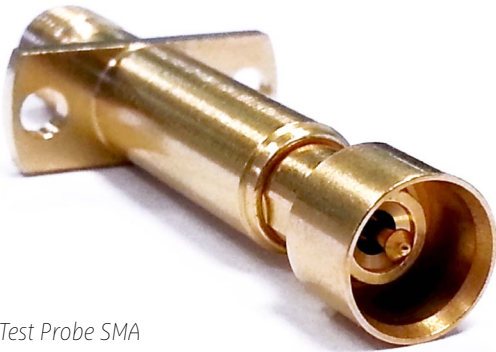

## RF Probe

A leader you can trust

**When production speed is an issue, trust Radiall's RF Probe to reduce test cycle time. Synergy's RF Probes are a perfect solution when connecting test equipment to device under test**



Test Probe SMA

Why let production slow down due to RF testing?

Test probes are widely used in the electronic industry for mass production, but too often RF connectors are tested separately.

With Radiall's RF Test Probes it is now easy to implement RF Flying tests to keep your production line at optimal speeds.

Innovative Flying RF Probes provide increased test speed, improved access, and greater fault coverage.

The shift from manual RF Testing is necessary to achieve the highest test coverage and maximum through-put. This is important in a competitive and constantly changing manufacturing environment.

Spring contact probes are designed for RF applications. The inner and outer conductors are mechanically designed to fit specific RF requirements. Due to this design, the signals within a wide frequency band are transmitted with a minimum loss.



Speed, efficiency and productivity are all demands in today's fast paced production environment. Radiall's RF Test Probe supports these requirements.

*A leader you can trust*

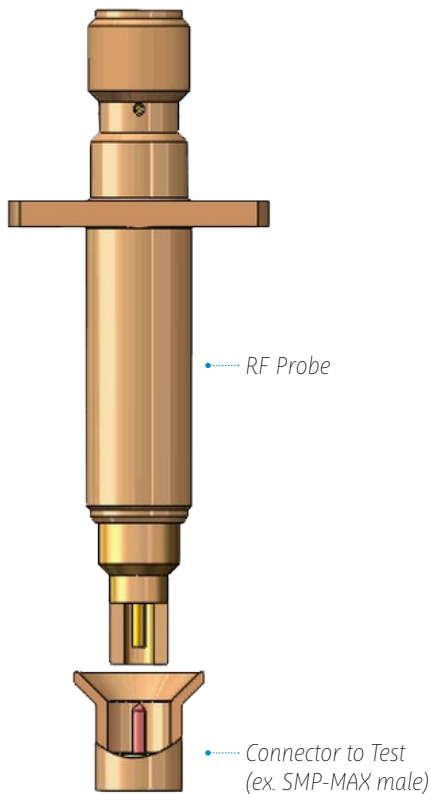

### Synergy RF test probe range:

Connector to test SMP male, SMP-MAX male, SMA female, MMBX female, SMB male.

RF probes consist of two independently spring-loaded units; spring-loaded inner and outer conductors.

The concentric design of the spring-loaded inner and outer conductors protects the coaxial conductor against external influences. When doing this, the energy between the inner and outer conductors is transferred in a similar fashion comparable to waveguide technology.

This co-axial design concept transfers both direct current and alternative current.

### Features & Benefits

- High frequency
- Long lasting
- Versatile design

### Applications

- Automatic PCB testing
- Production bench test